

Caston II

Crane Scale

- Available in 1000 lb × 0.5, 2000 lb × 1, or 5000 lb × 2 Capacities
- Battery Operated
- Easy to Read 1.2" LED Display
- Wireless Remote Control Standard



ISO 9001 certified

CAS
S · C · A · L · E

CASTON II Crane Scale

FEATURES

- Battery Operated w/ Low Battery Indication
- Rechargeable Battery Pack
- Spare Battery Pack and Charger Included as Standard
- Remote Control Included as Standard
- On, Off, Zero, and Tare Functions
- Easy to Read 1.2" LED Displays
- Auto Span Adjustment
- Auto Zero Tracking

SPECIFICATIONS

Model	0.5 THB	1 THB	2 THB
Weighing Capacity	1,000 × 0.5 lbs 500 × 0.2 kg	2000 × 1 lbs 1000 × 0.5 kg	5000 × 2 lbs 2000 × 1 kg
Maximum Tare	Full Tare		
Display Type	LED (1.2 inch)		
Operating Power	DC 6V		
Power Source	AC 120V, 60 Hz		
Display Designators	Zero, Tare, Batt.		
Power Consumption	1 W		
Operating Temperature	- 10 °C ~ +40 °C (14 °F ~ 104 °F)		
Product Weight	37.5 lb / 17 kg		

DIMENSIONS

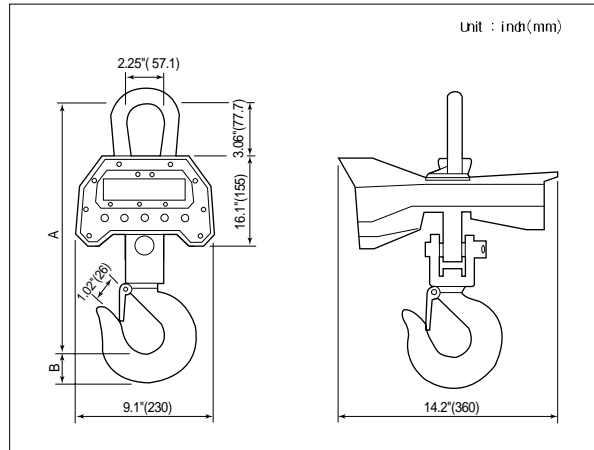

Model	A	B
0.5 THB	13.8" (350)	1.18" (30)
1 THB	13.8" (350)	1.18" (30)
2 THB	16.9" (430)	1.75" (44.5)



▲ Display & Keyboard



▶ Battery Pack Installation



CAS USA Corporation

NJ OFFICE
99 Murray Hill Parkway
East Rutherford, NJ 07073
Tel: (201) 933-9002
Fax: (201) 933-9025

<http://www.cas-usa.com>

CA OFFICE
733 S. State College Blvd #98
Fullerton, CA 92831
Tel: (714) 870-1286
Fax: (714) 870-1167