

Caston IV

Crane Scale

- Available in 1000 lb \times 0.5, 2000 lb \times 1, 5000 lb \times 2 or 10000 lb \times 5 Capacities
- Legal for Trade
- Easy to Read 1.2" LED Display
- Wireless Remote Control Standard
- Environmentally Sealed to IP 67 standards.



ISO 9001 certified

CAS
S · C · A · L · E

CASTON IV Crane Scale

FEATURES

- Battery Operated w/ Low Battery Indication
- Rechargeable Battery Pack
- Spare Battery Pack and Charger Included as Standard
- On, Off, Zero, Tare, and kg/lb Functions
- Easy to Read 1.2" LED Display
- Auto Span Adjustment
- Auto Zero Tracking

SPECIFICATIONS

| Model | 0.5 THC | 1 THC | 2 THC | 5 THC |
|-----------------------|--------------------------------|-------------------------------|-----------------------------|------------------------------|
| Weighing Capacity | 1000 x 0.5 lbs 500 x 0.2 kg | 2000 x 1 lbs 1000 x 0.5 kg | 5000 x 2 lbs 2000 x 1 kg | 10000 x 5 lbs 5000 x 2 kg |
| Maximum Tare | Full Tare | | | |
| Display Type | LED (1.2 inch) | | | |
| Operating Power | DC 6 V | | | |
| Power Source | AC 120 V, 50/ 60 Hz | | | |
| Display Designators | Zero, Tare, Batt. | | | |
| Power Consumption | 1.2 W | | | |
| Operating Temperature | - 10 °C ~ +40 °C | | | |
| Product Weight | 44 lb/20 kg | 62 lb/28 kg | 66 lb/30 kg | |

DIMENSIONS

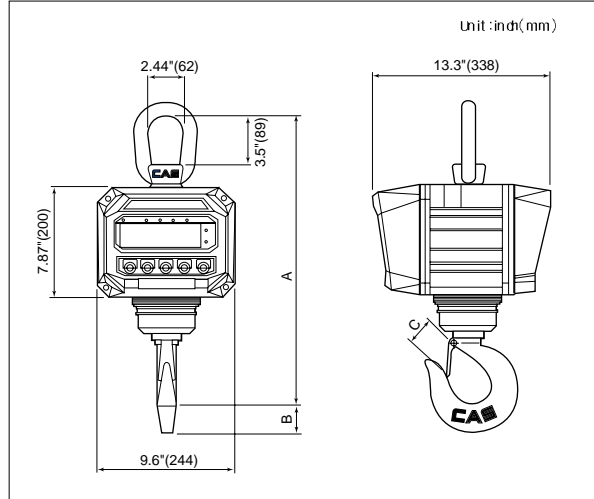

| Model | A | B | C |
|---------|-------------|------------|------------|
| 0.5 THC | 18.2" (463) | 1.14" (29) | 1.18" (30) |
| 1 THC | 18.2" (463) | 1.14" (29) | 1.18" (30) |
| 2 THC | 18.2" (463) | 1.77" (45) | 1.77" (45) |
| 5 THC | 21.4" (543) | 1.77" (45) | 1.77" (45) |



▲ Display & Key board



► Battery Pack Installation



CAS USA Corporation

NJ OFFICE
99 Murray Hill Parkway
East Rutherford, NJ 07073
Tel: (201) 933-9002
Fax: (201) 933-9025

<http://www.cas-usa.com>

CA OFFICE
733 S. State College Blvd #98
Fullerton, CA 92831
Tel: (714) 870-1286
Fax: (714) 870-1167